

LT Q1

Pyroelectric Single Element Detector for Measurement Applications

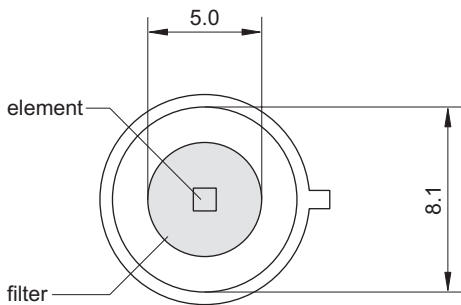
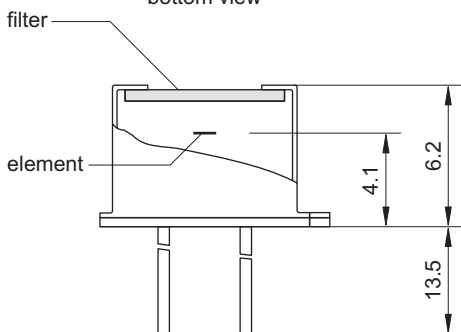
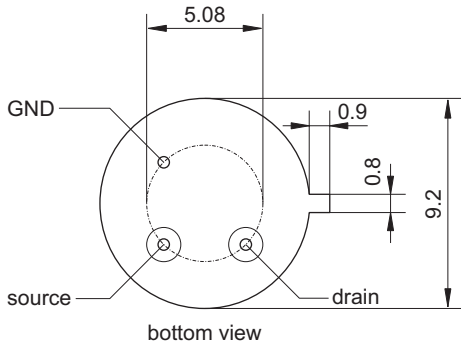

element size	1 mm × 1 mm
aperture	5.0 mm
filter ³	custom-designed
responsivity ^{1,2}	>1100 V/W
noise ¹	<500 nV/√Hz
specific detectivity ^{1,2}	>2·10 ⁸ cm √Hz/W
offset voltage	0.4 to 1.5 V
operating voltage	2 to 18 V
housing	TO 39
operating temperature	-20 to 70 °C
storage temperature	-20 to 70 °C

1) frequency: 10 Hz, detector temperature: 25 °C
 2) black body source temperature: 500 K, filter transmission: 100 %
 3) other filters on request

